

# FLUKE®

## 80PK-2A Type K Immersion Probe

### Instruction Sheet

#### WARNING

**TO AVOID ELECTRICAL SHOCK, DO NOT USE THIS PROBE WHEN VOLTAGES EXCEEDING 24V AC RMS OR 60V DC ARE PRESENT. THE PROBE TIP IS ELECTRICALLY CONNECTED TO THE OUTPUT TERMINALS.**

#### INTRODUCTION

The 80PK-2A Type K Thermocouple Immersion Probe is designed for use in liquids or gels. The probe can also be used as a general purpose temperature probe. The thermocouple junction is protected from tip to handle by an Inconel sheath. The 4-foot cable is terminated with a Type K miniature thermocouple connector with 0.792-mm (0.312-in) pin spacing. The 80PK-2A can be used with any temperature-measuring instrument that is designed to accept Type K thermocouples and has a miniature connector input.

#### NOTE

*The 80PK-2A is not recommended for use in food or beverage preparation.*

#### SPECIFICATIONS

**Type:** K Standard grade Ni-Cr vs. Ni-Al (Chromel vs. Alumel)

**Measurement Range:** -196°C to 1090°C (-320°F to 1994°F)

**Accuracy:** (With respect to ANSI MC96.1-1982-Standard Limits of Error)

#### NOTE

*All error calculations should be done in °C, then scaled to °F.*

<b>RANGE</b>	<b>ACCURACY (% of reading)</b>
-196°C to -110°C (-320°F to -166°F)	±4% (°C)
-110°C to -40°C (-166°F to -40°F)	±4.4°C
-40°C to 275°C (-40°F to 527°F)	±2.2°C
275°C to 1090°C (527°F to 1994°F)	±0.75% (°C)

PN 828780

November 1987 Rev. 3, 5/95

© 1987, 1993, 1995 Fluke Corporation. All rights reserved. Printed in U.S.A.  
All product names are trademarks of their respective companies.

**Output:** @ 25°C (77°F) = 1.00 mV (reference junction @ 0°C)

**Seebeck Coefficient:** @ 25°C (77°F) = 40.50  $\mu\text{V} / ^\circ\text{C}$

**Measurement Time:** (Time Constant): .75 seconds in 100°C still water at sea level pressure. Complete step change equals 5 time constants (3.75 seconds).

**Maximum Voltage:** 24V ac rms or 60V dc

**Maximum Temperature of Tip:** 1090°C (1994°F)

### **Sheath:**

Material: Inconel 600

Dimensions:

Diameter: 3.175 mm (1/8 in)

Length: 20.32 cm (8 in)

**Grounding:** Junction welded to sheath.

### **Cable:**

Length: 1.2 meters (4 ft) Insulation

Material: PVC

Maximum Temperature: 105°C (220°F)

Jacket Color: Gray

### **Conductors:**

Type: K

Size: AWG #24 stranded (7 strands of #32)

### **Handle:**

Material: Gray Hytrel

Maximum Temperature: 125°C (257°F)

### **Connector:**

Type: Mini-thermocouple connector with .792 mm (0.312 in) pin spacing

Material: Yellow Hytrel

Maximum Temperature: 125°C (257°F)

**Overall Length:** 31.75 cm (12.5 in) from probe tip to end of cable strain relief.

**Protection:** Class 3. Relates solely to insulation and grounding properties defined in IEC 348.

## **MEASUREMENT CONSIDERATIONS**

### **Instrument Compatibility**

The 80PK-2A is compatible with any temperature-measuring instrument that accepts Type K thermocouples, has a miniature thermocouple connector, and has cold reference junction compensation. Accuracy of the temperature-measuring instrument must be considered along with the 80PK-2A accuracy specification to determine the overall accuracy of the combination.

### **Temperature Limitations**

The probe tip of the 80PK-2A has a continuous temperature rating of 1090°C (1994°F). However the opposite end of the sheath nearest the handle should not be subjected to temperatures greater than 125°C (257°F). This is the maximum temperature limitation of the handle.

### **Media Limitations**

The sheath material of the 80PK-2A is Inconel, an alloy of chromium and nickel. It has excellent resistance to oxidation and corrosion at high temperatures, but it should not be used in the presence of sulfur above 537°C (1000°F).

## **OPERATION**

Use the 80PK-2A as follows:

1. Connect the 80PK-2A to a compatible Type K temperature measuring instrument using the miniature (0.312-inch pin spacing) thermocouple connector.
2. Turn on the measuring instrument, and select the appropriate range and scale.
3. Check the readout on the measuring instrument. With no heat or cold source applied to the tip of the probe, the measuring instrument should display the ambient (room) temperature. If the instrument does not read out properly, refer to the TROUBLESHOOTING paragraphs below.

## **MINIMIZING THERMAL SHUNTING**

The 80PK-2A Immersion Probe should be inserted at least 6.35 cm (2.5 in) into the environment to be measured to minimize the shunting effect of the sheath.

## **TROUBLESHOOTING**

With no heat or cold applied to the probe, the measuring instrument should display the ambient temperature. If the measuring instrument does not read out properly, try the following:

1. Verify that the temperature-measuring instrument is designed to be used with Type K thermocouples. The temperature-measuring instrument should have a yellow input connector and / or be marked with a "K" either on the case or on the display.
2. Check for an open circuit indicator on the measuring instrument. Some temperature measuring instruments have a built-in circuit to indicate if the connected probe is open. (All Fluke Temperature-measuring instruments have this feature.) Refer to the owners manual accompanying the measuring instrument to see if this feature is available.

Short the two input pins of the measuring instrument with a piece of wire. If the instrument is functioning, it should indicate the ambient temperature.

3. If you suspect a broken connection, use an ordinary ohmmeter to read the continuity of the probe from pin to pin. The ohmmeter should read 10 ohms or less if there is continuity.

## **SCALE CONVERSIONS**

Use the following equation to convert °C to °F:

$$(^{\circ}\text{C} \times 1.8) + 32 = ^{\circ}\text{F}$$

Use the following equation to convert °F to °C:

$$(^{\circ}\text{F} - 32) \times 0.5556 = ^{\circ}\text{C}$$

## **PROBE MOUNTING GROOVE**

The probe finger guard contains a groove to simplify mounting the probe in a fixed position. The figure below shows nominal dimensions for the finger guard and groove, and suggests a temporary quick mounting method. However, any mounting method should be carefully designed to prevent damage to the probe or the measured medium.

### **CAUTION**

**The handle and plug of the probe are made of material that may deteriorate when exposed to some solvents on a long-term basis.**

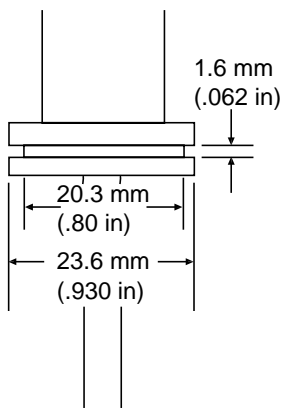

CLIP NOT INCLUDED WITH PROBE

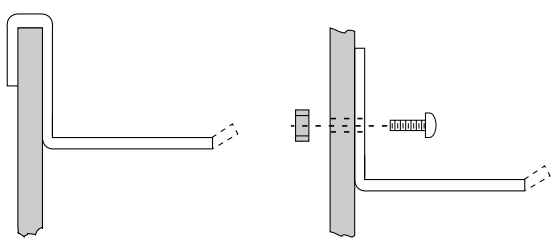
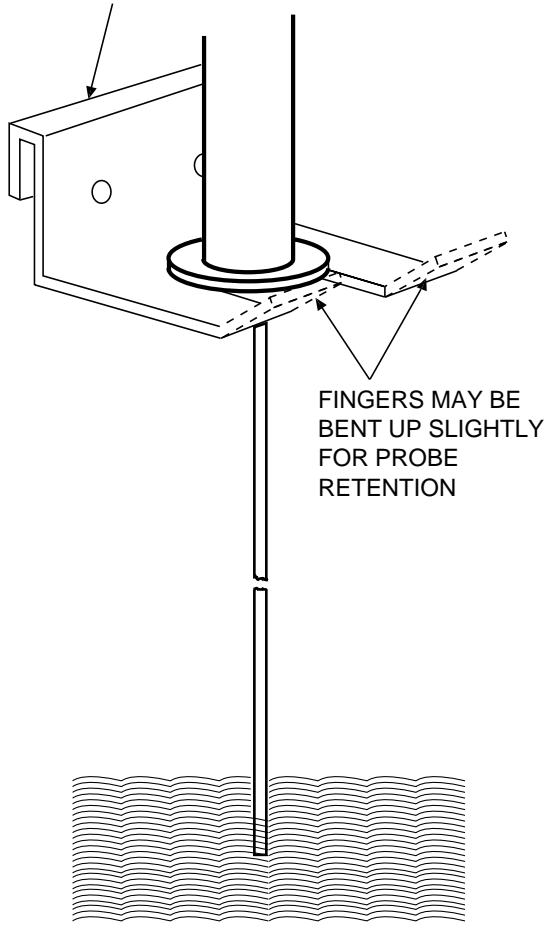

## LIMITED WARRANTY & LIMITATION OF LIABILITY

Each Fluke product is warranted to be free from defects in material and workmanship under normal use and service. The warranty period is one year and begins on the date of shipment. Parts, product repairs and services are warranted for 90 days. This warranty extends only to the original buyer or end-user customer of a Fluke authorized reseller, and does not apply to fuses, disposable batteries or to any product which, in Fluke's opinion, has been misused, altered, neglected or damaged by accident or abnormal conditions of operation or handling. Fluke warrants that software will operate substantially in accordance with its functional specifications for 90 days and that it has been properly recorded on non-defective media. Fluke does not warrant that software will be error free or operate without interruption.

Fluke authorized resellers shall extend this warranty on new and unused products to end-user customers only but have no authority to extend a greater or different warranty on behalf of Fluke. Warranty support is available if product is purchased through a Fluke authorized sales outlet or Buyer has paid the applicable international price. Fluke reserves the right to invoice Buyer for importation costs of repair/replacement parts when product purchased in one country is submitted for repair in another country.

Fluke's warranty obligation is limited, at Fluke's option, to refund of the purchase price, free of charge repair, or replacement of a defective product which is returned to a Fluke authorized service center within the warranty period.

To obtain warranty service, contact your nearest Fluke authorized service center or send the product, with a description of the difficulty, postage and insurance prepaid (FOB Destination), to the nearest Fluke authorized service center. Fluke assumes no risk for damage in transit. Following warranty repair the product will be returned to Buyer, transportation prepaid (FOB Destination). If Fluke determines that the failure was caused by misuse, alteration, accident or abnormal condition of operation or handling, Fluke will provide an estimate of repair costs and obtain authorization before commencing the work. Following repair, the product will be returned to the Buyer transportation prepaid and the Buyer will be billed for the repair and return transportation charges (FOB Shipping Point).

**THIS WARRANTY IS BUYER'S SOLE AND EXCLUSIVE REMEDY AND IS IN LIEU OF ALL OTHER WARRANTIES, EXPRESS OR IMPLIED, INCLUDING BUT NOT LIMITED TO ANY IMPLIED WARRANTY OF MERCHANTABILITY OR FITNESS FOR A PARTICULAR PURPOSE. FLUKE SHALL NOT BE LIABLE FOR ANY SPECIAL, INDIRECT, INCIDENTAL OR CONSEQUENTIAL DAMAGES OR LOSSES, INCLUDING LOSS OF DATA, WHETHER ARISING FROM BREACH OF WARRANTY OR BASED ON CONTRACT, TORT, RELIANCE OR ANY OTHER THEORY.**

Since some countries or states do not allow limitation of the term of an implied warranty, or exclusion or limitation of incidental or consequential damages, the limitations and exclusions of this warranty may not apply to every buyer. If any provision of this Warranty is held invalid or unenforceable by a court of competent jurisdiction, such holding will not effect the validity or enforceability of any other provision.

**For application or operation assistance, or information on Fluke products, call:**

**USA: 1-888-99-FLUKE (1-888-993-5853)**

**Canada: 1-800-36-FLUKE (1-800-363-5853)**

**Europe: +31 402-678-200**

**Japan: +81-3-3434-0181**

**Singapore: +65-738-5655**

**Anywhere in the world: +1-425-446-5500**

**Or, visit Fluke's Web site at [www.fluke.com](http://www.fluke.com).**

**Address correspondence to:**

**Fluke Corporation**

**P.O. Box 9090**

**Everett, WA 98206-9090**

**USA**

**Fluke EuropeB.V.**

**P.O. Box 1186**

**5602 BD Eindhoven,**

**The Netherlands**